

4

3

2

1

B

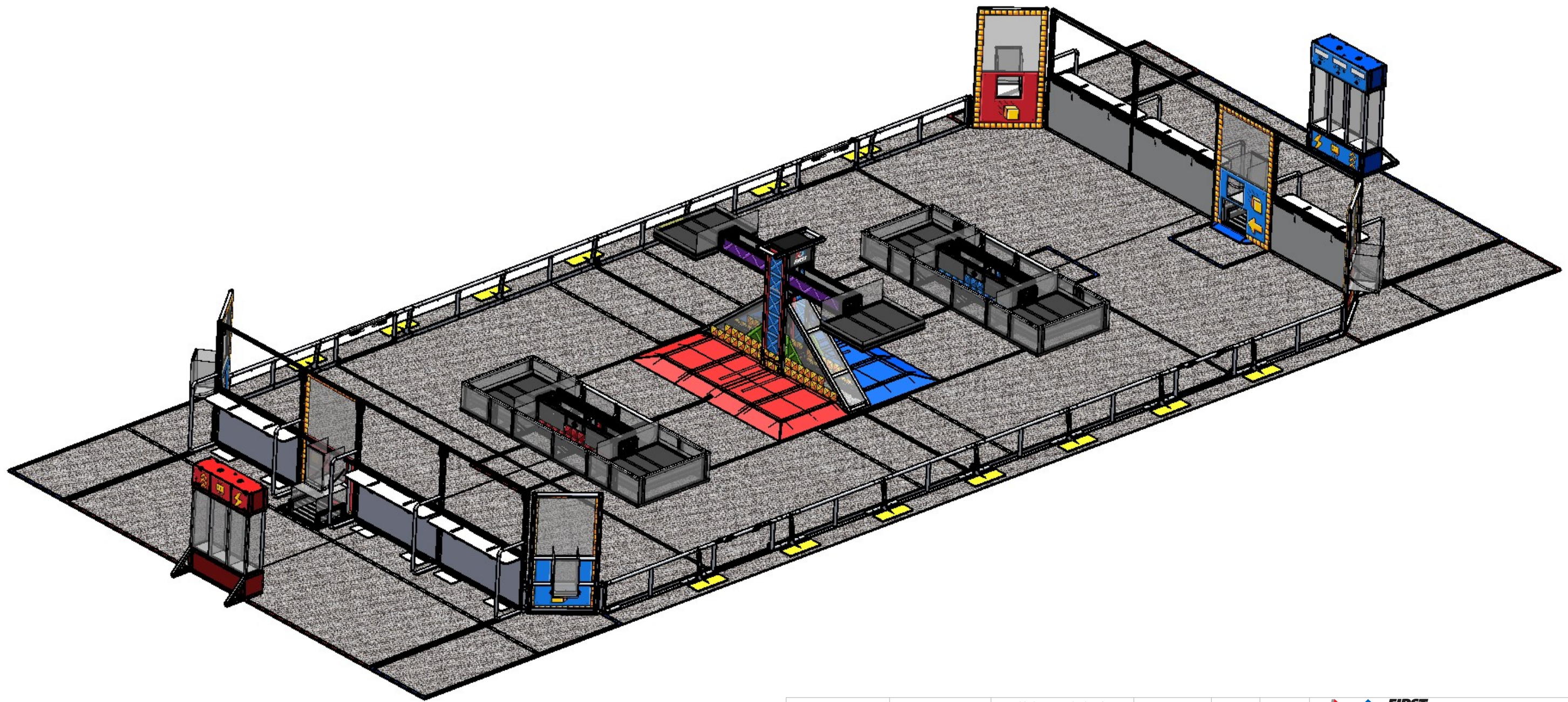

B



A

A

PROPRIETARY AND CONFIDENTIAL
 THE INFORMATION CONTAINED IN THIS DRAWING IS THE SOLE PROPERTY OF FIRST®. ANY REPRODUCTION IN PART OR AS A WHOLE WITHOUT THE WRITTEN PERMISSION OF FIRST® IS PROHIBITED.

		UNLESS OTHERWISE SPECIFIED:	NAME	DATE	 
		DIMENSIONS ARE IN INCHES TOLERANCES: FRACTIONAL ±1/16 ANGULAR: MACH ±1° BEND ±1° TWO PLACE DECIMAL ±.01 THREE PLACE DECIMAL ±.001	DRAWN		
		INTERPRET GEOMETRIC TOLERANCING PER:	CHECKED		SIZE DWG. NO. REV
		MATERIAL	ENG APPR.		B FE-00041
		FINISH	MFG APPR.		SCALE: 1:60 WEIGHT: SHEET 1 OF 4
NEXT ASSY	USED ON		Q.A.		
APPLICATION		DO NOT SCALE DRAWING	COMMENTS:		

4

3

2

1

4

3

2

1

B

B

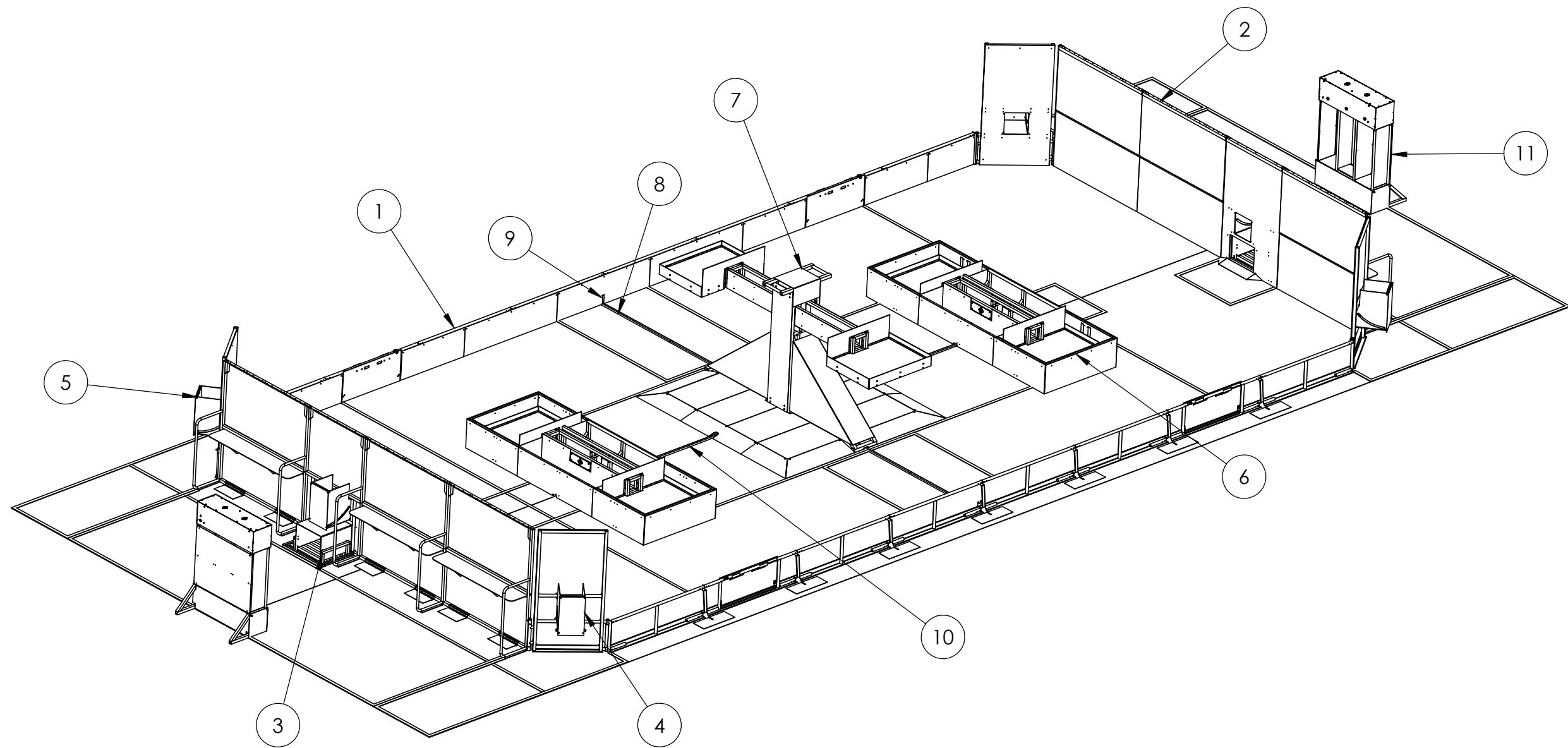



A

A

ITEM NO.	PART NUMBER	DESCRIPTION	Default/ QTY.
1	FE-00041-02	Side Border	2
2	FE-00041-03	End Wall	2
3	GE-18100	Assembly, Exchange	2
4	GE-18108	Portal - Left	2
5	GE-18109	Portal - Right	2
6	GE-18112	Switch Assembly	2
7	GE-18120	Scale Assembly	1
8	GE-18117	Long Mitered Wire Protector	2
9	GE-18118	Short Mitered Wire Protector	2
10	GE-18116	Long Wire Protector	6
11	GE-18126	Vault Assembly	2

PROPRIETARY AND CONFIDENTIAL
 THE INFORMATION CONTAINED IN THIS DRAWING IS THE SOLE PROPERTY OF FIRST®. ANY REPRODUCTION IN PART OR AS A WHOLE WITHOUT THE WRITTEN PERMISSION OF FIRST® IS PROHIBITED.

		UNLESS OTHERWISE SPECIFIED:	NAME	DATE	 
		DIMENSIONS ARE IN INCHES TOLERANCES: FRACTIONAL ±1/16 ANGULAR: MACH ±1° BEND ±1° TWO PLACE DECIMAL ±.01 THREE PLACE DECIMAL ±.001	DRAWN		
		INTERPRET GEOMETRIC TOLERANCING PER:	CHECKED		SIZE DWG. NO. REV
		MATERIAL	ENG APPR.		B FE-00041
NEXT ASSY	USED ON	FINISH	MFG APPR.		SCALE: 1:70 WEIGHT: SHEET 2 OF 4
APPLICATION		DO NOT SCALE DRAWING	Q.A.		
			COMMENTS:		

4

3

2

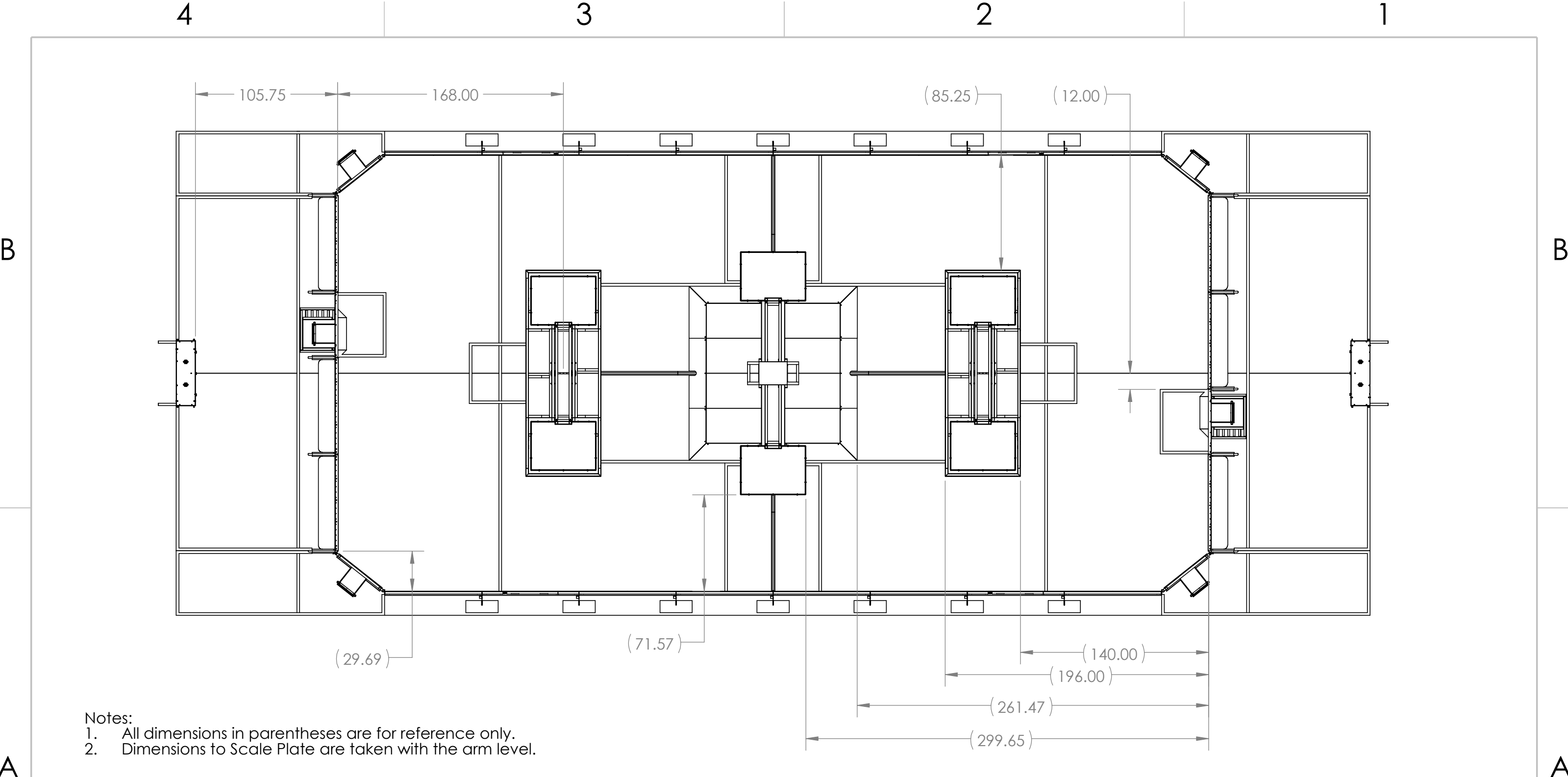

1



- Notes:
1. All dimensions in parentheses are for reference only.
 2. Dimensions to Scale Plate are taken with the arm level.

PROPRIETARY AND CONFIDENTIAL
 THE INFORMATION CONTAINED IN THIS DRAWING IS THE SOLE PROPERTY OF FIRST®. ANY REPRODUCTION IN PART OR AS A WHOLE WITHOUT THE WRITTEN PERMISSION OF FIRST® IS PROHIBITED.

UNLESS OTHERWISE SPECIFIED:		NAME	DATE
DIMENSIONS ARE IN INCHES		DRAWN	
TOLERANCES:		CHECKED	
FRACTIONAL: ±1/16		ENG APPR.	
ANGULAR: MACH ±1° BEND ±1°		MFG APPR.	
TWO PLACE DECIMAL ±.01		Q.A.	
THREE PLACE DECIMAL ±.001		COMMENTS:	
INTERPRET GEOMETRIC TOLERANCING PER:			
MATERIAL			
FINISH			
NEXT ASSY	USED ON		
APPLICATION			
DO NOT SCALE DRAWING			

 		
TITLE:		
2018 Field Layout and Marking		
SIZE	DWG. NO.	REV
B	FE-00041	
SCALE: 1:70 WEIGHT:		SHEET 3 OF 4

4

3

2

1

B

B

A

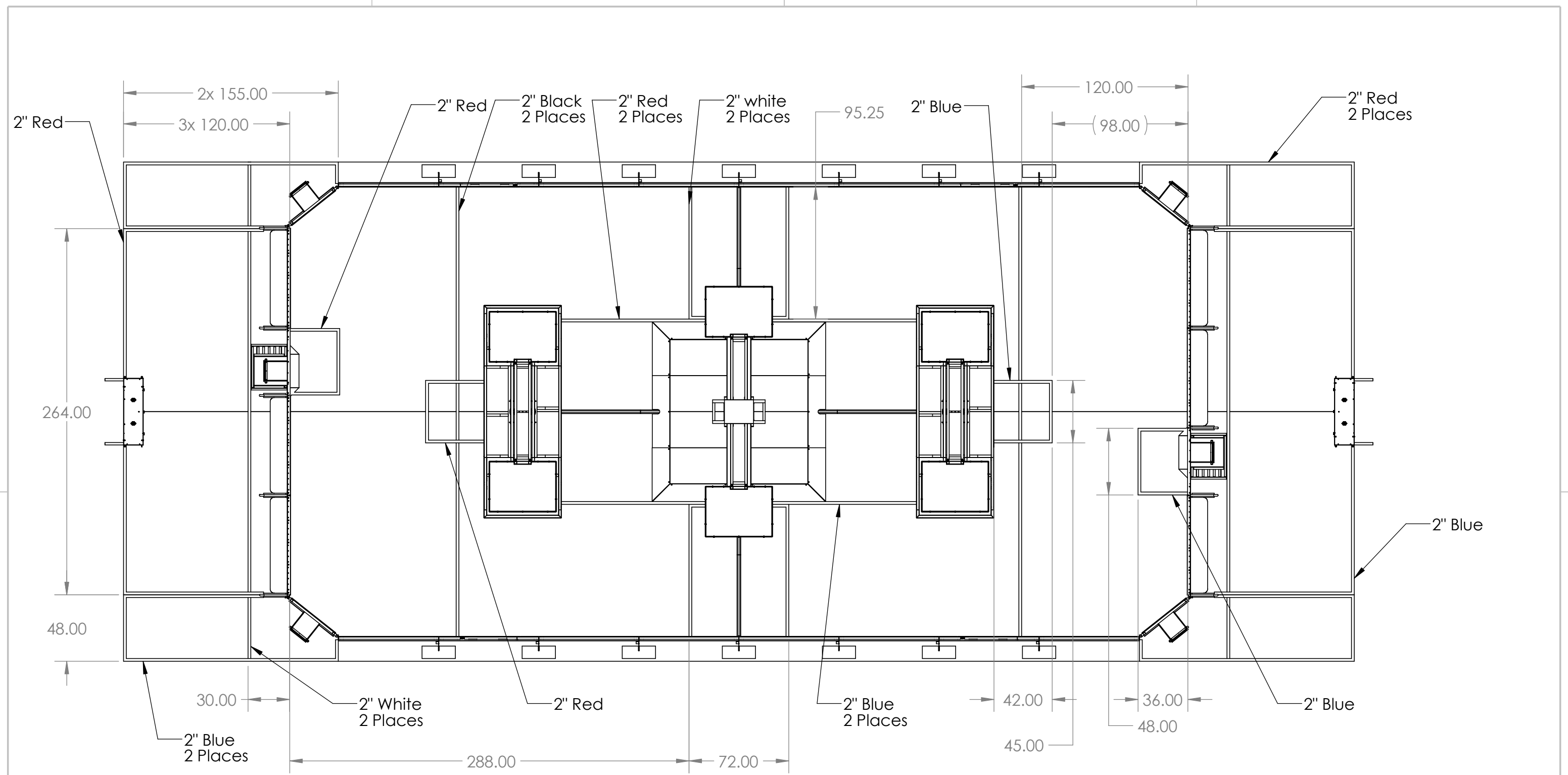

A



Notes:
 1. All dimensions in parentheses are for reference only.

PROPRIETARY AND CONFIDENTIAL
 THE INFORMATION CONTAINED IN THIS DRAWING IS THE SOLE PROPERTY OF FIRST®. ANY REPRODUCTION IN PART OR AS A WHOLE WITHOUT THE WRITTEN PERMISSION OF FIRST® IS PROHIBITED.

		UNLESS OTHERWISE SPECIFIED:		NAME	DATE
		DIMENSIONS ARE IN INCHES		DRAWN	
		TOLERANCES:		CHECKED	
		FRACTIONAL: ±1/16		ENG APPR.	
		ANGULAR: MACH ±1° BEND ±1°		MFG APPR.	
		TWO PLACE DECIMAL ±.01		Q.A.	
		THREE PLACE DECIMAL ±.001		COMMENTS:	
		INTERPRET GEOMETRIC TOLERANCING PER:			
		MATERIAL			
		FINISH			
NEXT ASSY	USED ON				
APPLICATION		DO NOT SCALE DRAWING			

TITLE:

2018 Field Layout and Marking

SIZE	DWG. NO.	REV
B	FE-00041	

SCALE: 1:70 WEIGHT: SHEET 4 OF 4

4

3

2

1

4

3

2

1

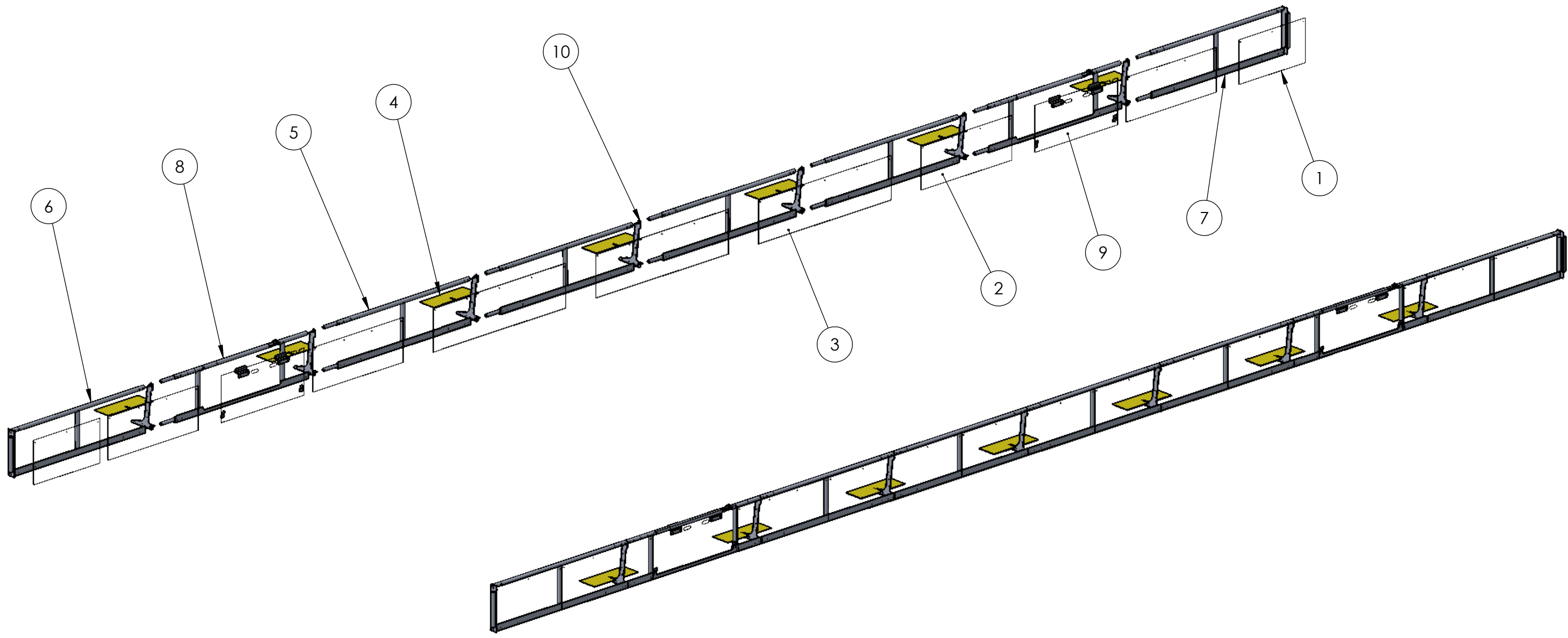

B



B

A

A

ITEM NO.	PART NUMBER	DESCRIPTION	QTY.
1	FE-00008	Field Plastic "A"	2
2	FE-00009	Field Plastic "B"	4
3	FE-00010	Field Plastic "C"	3
4	FE-00015	Trip Guard	7
5	FE-00022	Field Rail Assy - Mid	4
6	FE-00023	Field Rail Assy - Left	1
7	FE-00024	Field Rail Assy - Right	1
8	FE-00029	Field Gate, Assembly	2
9	FE-00047	Gate Plastic Assembly	2
10	FE-00050	Outrigger	7

PROPRIETARY AND CONFIDENTIAL
 THE INFORMATION CONTAINED IN THIS DRAWING IS THE SOLE PROPERTY OF **FIRST®**. ANY REPRODUCTION IN PART OR AS A WHOLE WITHOUT THE WRITTEN PERMISSION OF **FIRST®** IS PROHIBITED.

		UNLESS OTHERWISE SPECIFIED:	NAME	DATE	 
		DIMENSIONS ARE IN INCHES TOLERANCES: FRACTIONAL ±1/16 ANGULAR: MACH ±1° BEND ±1° TWO PLACE DECIMAL ±.01 THREE PLACE DECIMAL ±.001	DRAWN		
		INTERPRET GEOMETRIC TOLERANCING PER:	CHECKED		SIZE DWG. NO. REV B FE-00041-02
		MATERIAL	ENG APPR.		
NEXT ASSY	USED ON	FINISH	MFG APPR.		SCALE: 1:40 WEIGHT: SHEET 1 OF 1
APPLICATION		DO NOT SCALE DRAWING	Q.A.	COMMENTS:	

4

3

2

1

4

3

2

1

B

B

A

A

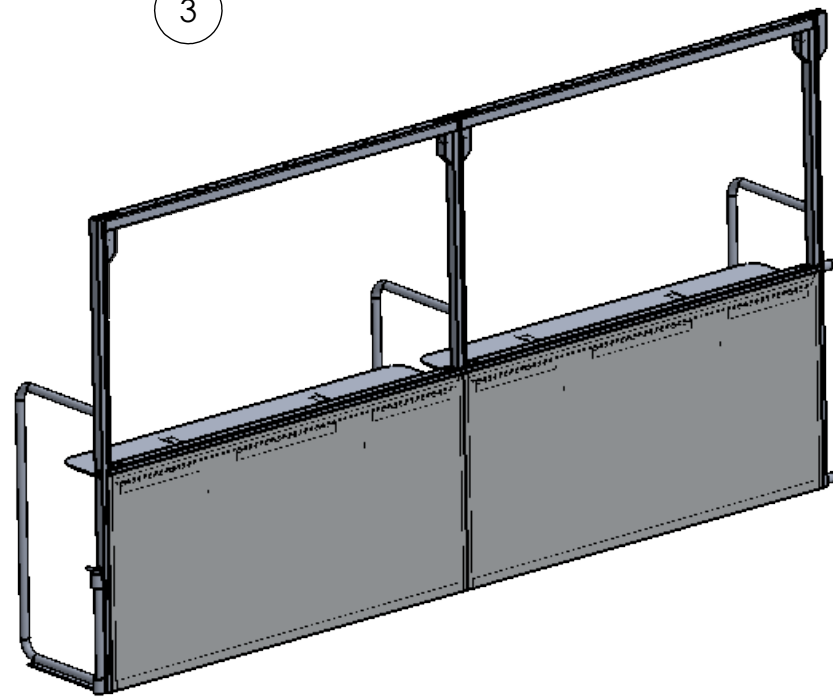
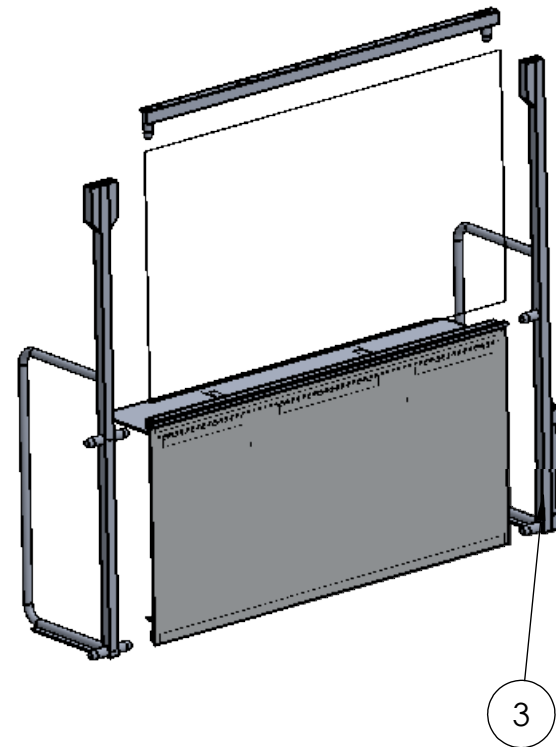
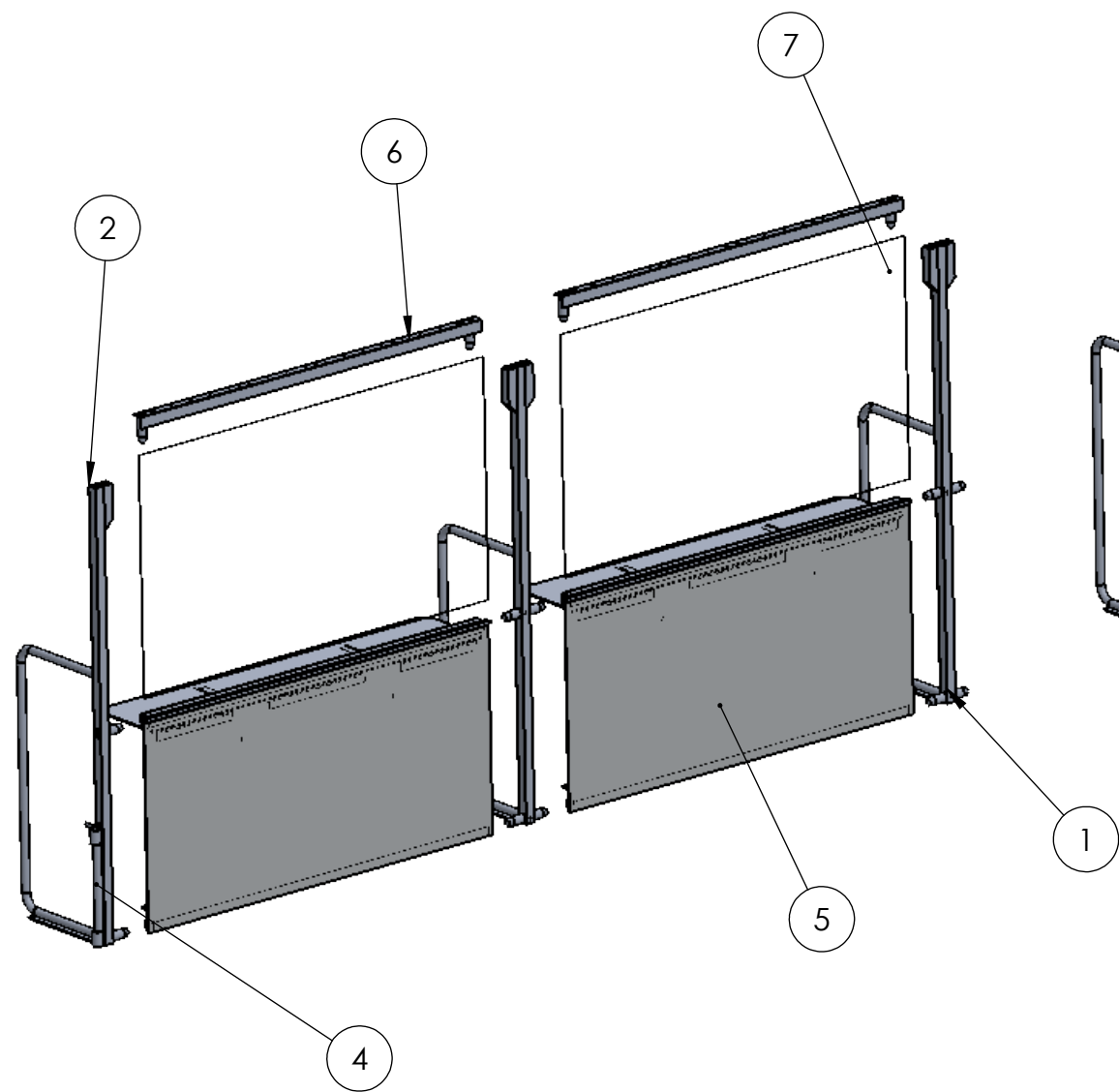

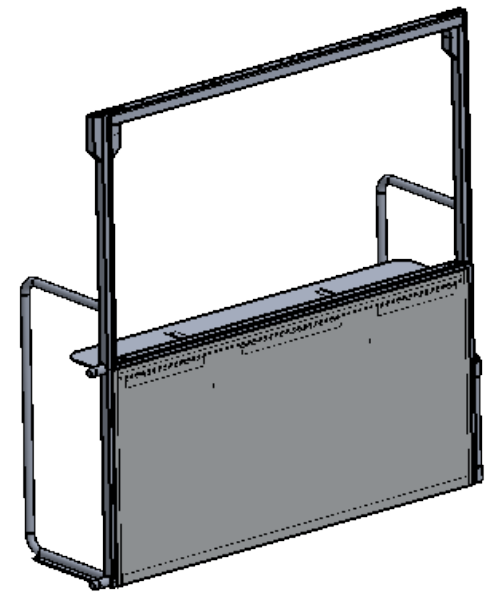

Assembly, Exchange, GE-18100,
to be attached here



ITEM NO.	PART NUMBER	DESCRIPTION	QTY.
1	FE-00001	Drivers Station Support	3
2	FE-00002_Left	Corner Supports, Left	1
3	FE-00002	Corner Supports, Right	1
4	FE-00003	Rail Pin Assy	2
5	FE-00004	End Panel	3
6	FE-00007	Field Top Rail	3
7	FE-00012	Drivers Station Acrylic	3

PROPRIETARY AND CONFIDENTIAL
THE INFORMATION CONTAINED IN THIS DRAWING IS THE SOLE PROPERTY OF **FIRST®**. ANY REPRODUCTION IN PART OR AS A WHOLE WITHOUT THE WRITTEN PERMISSION OF **FIRST®** IS PROHIBITED.

		UNLESS OTHERWISE SPECIFIED:	NAME	DATE
		DIMENSIONS ARE IN INCHES	DRAWN	
		TOLERANCES:	CHECKED	
		FRACTIONAL: ±1/16	ENG APPR.	
		ANGULAR: MACH ±1° BEND ±1°	MFG APPR.	
		TWO PLACE DECIMAL ±.01	Q.A.	
		THREE PLACE DECIMAL ±.001	COMMENTS:	
		INTERPRET GEOMETRIC TOLERANCING PER:		
		MATERIAL		
NEXT ASSY	USED ON	FINISH		
APPLICATION		DO NOT SCALE DRAWING		

TITLE: **End Wall**

SIZE DWG. NO. REV
B FE-00041-03

SCALE: 1:30 WEIGHT: SHEET 1 OF 1

4

3

2

1